

Manual on rack mounted Li-ion battery

Product Model:

LFR48100 / LFR48200 / LFR51100 / LFR51200

File Version: V1.1





Revision record



number	version	revision content	revision date	Compilation
1	V1.0	first edition	2023/12/18	
2	V1.1	Add product information for model LFR48100/LFR48200	2024/01/17	



Contents



1. Safety instructions	1
2. Introduction to Basic Functions of Rack mounted Battery	4
3. Structure and Function Description of Rack Battery Products	8
4. Installation and usage instructions for rack batteries	10
5. Screen operation instructions.....	20
6. Storage instructions	27
7. Declaration.....	28

1. Safety instructions

<p> Danger: If there is no standardized operation, it may lead to accidents such as fire, serious personal injury, and even death.</p> <p> Attention: If there is no standardized operation, it may cause moderate or minor personal injury, as well as system failure or damage. When installing, using, and repairing this system, please read this manual carefully and be sure to follow the safety precautions required in this chapter! Any injury or loss caused by illegal operations is not related to our company!</p>	
Usefulness	<p> Danger</p>
	<ul style="list-style-type: none">◆ This series of battery packs must be used together with the compatible inverter, otherwise it may cause system damage.◆ This series of battery packs is used for energy storage and cannot be used for other purposes, as it may cause system malfunctions or fires.
Arrival inspection	<p> Attention</p>
	<ul style="list-style-type: none">◆ If system components are found to be damaged, they cannot be installed. Please communicate and confirm with the manufacturer in a timely manner, otherwise it may affect the project application.

	<ul style="list-style-type: none"> ◆ If it is found that the packing list does not match the physical name, communicate and confirm with the manufacturer in a timely manner, otherwise it may affect the project application.
Install	 Attention
	<ul style="list-style-type: none"> ◆ when handling and installing, please handle with care, otherwise it may cause system damage. ◆ This system should be kept away from flammable and explosive materials and heat sources.
Assembly wiring	 Danger
	<ul style="list-style-type: none"> ◆ Installation must be guided by qualified electrical engineering personnel who are familiar with the system, otherwise there is a risk of electric shock or damage to the system. ◆ Before wiring, it is necessary to ensure that the power supply is disconnected, otherwise there is a risk of electric shock or fire.
	 Attention
	<ul style="list-style-type: none"> ◆ Confirm if the communication wiring is correct, otherwise it may cause abnormal operation

	<ul style="list-style-type: none"> ◆ Confirm whether the positive and negative pole connections of the power supply are correct, otherwise it may cause system damage.
Running	 Danger
	<ul style="list-style-type: none"> ◆ Only after proper connection can the power be turned on. It is strictly prohibited to plug and unplug the wiring harness when the power is on, otherwise there is a risk of electric shock. ◆ Non system familiar professionals are not allowed to change the parameters of the upper computer settings page without authorization, otherwise it may cause system malfunctions or even accidents.
	 Attention
	<ul style="list-style-type: none"> ◆ Before running, please confirm whether this system is within the allowable range of use, otherwise it may cause damage to the system. ◆ Before operation, please confirm that the positive and negative wiring screws are tightened, otherwise it may cause system damage
Maintenance	 Danger
	<ul style="list-style-type: none"> ◆ If you want to disassemble the casing,

<p>Inspection</p>	<p>please make sure to turn off the power, otherwise there is a risk of electric shock.</p> <ul style="list-style-type: none"> ◆ Please designate qualified electrical engineering personnel for maintenance, inspection, or replacement of components, otherwise accidents may occur.
<p>Others</p>	<div data-bbox="490 424 633 469" style="border: 1px solid black; padding: 2px; margin-bottom: 10px;">  Danger </div> <ul style="list-style-type: none"> ◆ Do not squeeze, puncture, drop, vibrate, heat or short-circuit, and keep away from corrosive substances. ◆ Do not disassemble the battery by yourself. Incorrect disassembly can cause short circuits and other problems such as fire, gas, and even explosion; ◆ Do not place the battery in a fire. Otherwise, it may cause very dangerous situations such as fire and explosion. <div data-bbox="490 1018 660 1062" style="border: 1px solid black; padding: 2px; margin-bottom: 10px;">  Attention </div> <ul style="list-style-type: none"> ◆ If deformation, swelling, leakage or other issues are found, please do not use. ◆ Do not place the battery in substances such as water or liquids.

2. Introduction to Basic Functions of Rack mounted Battery

This product is a rack mounted lithium battery pack that can be combined with an adaptive inverter to form a household energy storage system. AC mains electricity (or solar energy generated through photovoltaic panels) is converted into appropriate voltage range DC electricity through an inverter to charge the battery pack and store electrical energy for use when needed. When battery storage is needed, the electricity from the lithium battery pack is converted into alternating current (grid connected or off grid, depending on user needs and inverter functions) through an inverter to supply power to the user's electrical equipment.

The product shapes of LFR48100, LFR51100, and LFR51200 rack batteries are shown in the following figures:

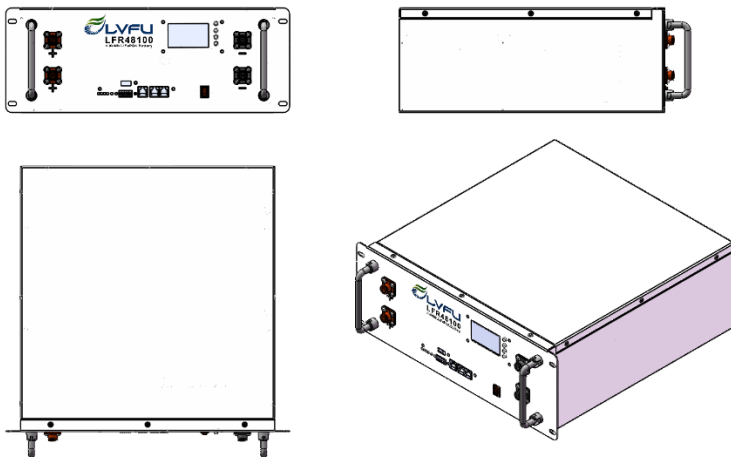

Figure 1. External view of LFR48100/LFR51100(The model logo is different)

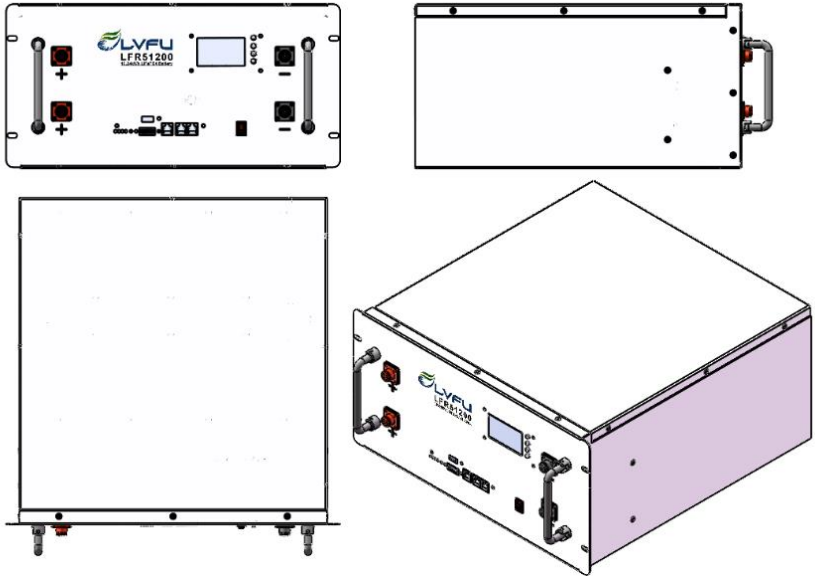

Figure 2. External view of LFR48200/LFR51200(The model logo is different)

The application scenario is shown in the figure:

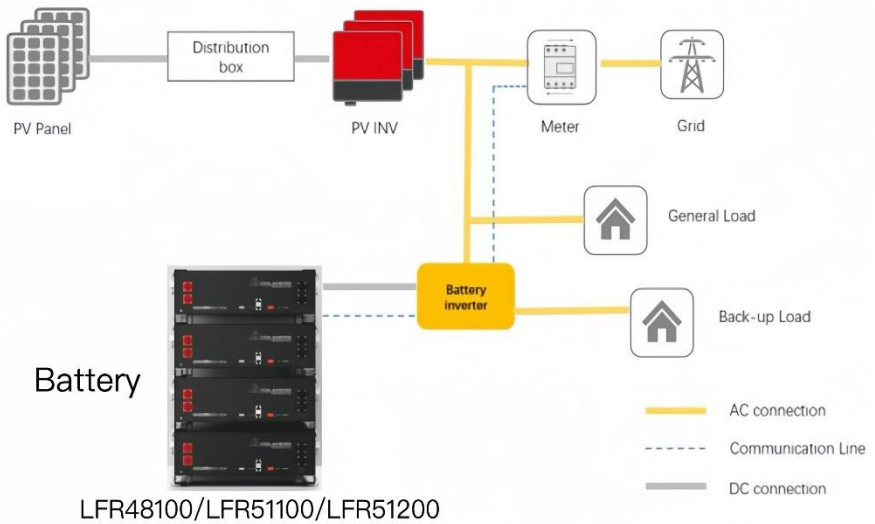

Figure 3. Application scenario diagram

The technical parameters of the battery are shown in the table below

Table 1. Technical parameters of rack battery LFR48100/LFR48200/LFR51100/LFR51200

Type		LFR48100	LFR48200	LFR51100	LFR51200
Product Specification		48V100Ah	48V200Ah	51V100Ah	51V200Ah
Battery parameters	Battery type	LFP(LiFePO4)			
	Nominal voltage(V)	48		51.2	
	Charging voltage range (V)	40.5-54		43.2-57.6	
	Equal charging voltage(V)	54		57.6	
	Max charging current(A)	50			
	Float charging voltage(V)	51		54	
	Charging current reduction opening conditions	total voltage \geq 52.5V, or		total voltage \geq 56V, or	
		Cell voltage \geq 3.5V			
	Charging current reduction value(A)	\leq 10			
	Charging cut-off conditions	total voltage \geq 54V		total voltage \geq 57.6V	
		Cell voltage \geq 3.63V			
	Max discharge current(A)	100			
	Discharging cut-off conditions	SOC \leq 15%, or			
		Total voltage \leq 43.5V, or		Total voltage \leq 46.4V, or	
Cell voltage \leq 2.9V					
Rated capacity*(Ah)	100	200	100	200	
Rated energy(kWh)	4.8	9.6	5.12	10.24	
General characteristics	Dimensions(W*D*H)	482.6*468*	482.6*488*	482.6*468*	482.6*488*
		178mm	237mm	178mm	237mm
	Battery pack weight(Kg)	49 \pm 3	81 \pm 3	50 \pm 3	83 \pm 3

*The rated capacity represents the discharge current at 0.5 C at 25 \pm 5 ° C and 0.5 C at the cut-off state after 30 min of rest

3. Structure and Function Description of Rack Battery Products

Taking LFR51100 rack battery as an example, the battery interface and definition are as follows:

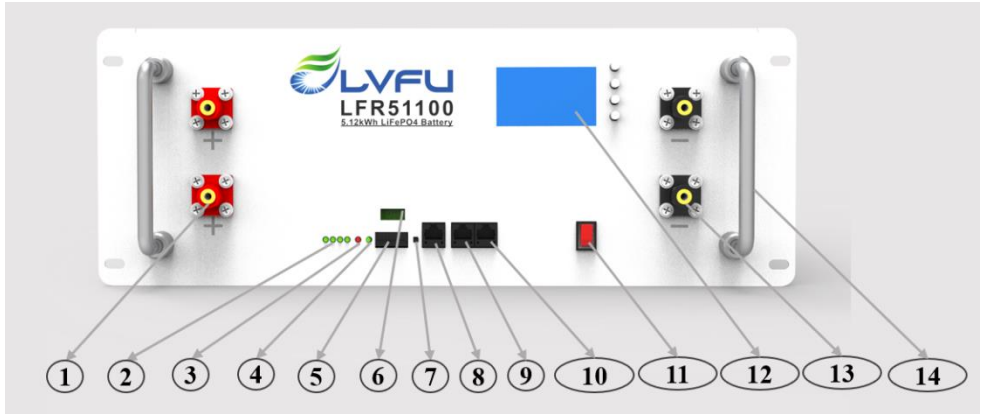

Figure 4. Rack Battery Interface Diagram

Table 2. Detailed Definition of Rack Battery Interface

ref	Interface device	Screen identification	Function Description
1	Positive terminal	+	Battery positive output terminal
2	Battery energy indicator	SOC	Display battery capacity status
3	Alarm indicator light	ALM	Display alarm status
4	Operation indicator	RUN	Display running status
5	DIP switch	ADDR	Set RS485 communication address

6	DRY CONTACT	I/O	Output electrical signal (reserved)
7	RESET button	RST	Control the startup and shutdown of BMS
8	RJ45 interface	CAN/485	Communication interface with inverter
9	RJ45 interface	RS485A	Parallel interface - input
10	RJ45 interface	RS485B	Parallel interface - output
11	Rocker switch	Wake up	Control the startup and shutdown of BMS
12	Display screen	/	Display battery operation and alarm information
13	Negative terminal	/	Battery negative output terminal
14	Foldable handle	/	Handle for handling batteries

3.2 Definition of communication line pins

BMS has RS485 communication for battery pack integration, with a baud rate of 1920bps. The RS485 communication interface adopts an 8P8C network cable interface. RS485 communication interface definition:

In Figure 5, Interface 8 is the communication interface between the battery and inverter, and Interface 9 and 10 are the parallel interfaces between the batteries.

The definition of interface 8 (CAN/485) is as follows:

Item	Crystal head picture	Serial no.	Definition
		1	RS485_B
		2	RS 485_A
		3	GND_COM
		4	CANH
		5	CANL
		6	GND_COM
		7	RS 485_A
		8	RS485_B

Figure 5. Definition of communication line pins

The definitions of interface 9 (RS485A) and interface 10 (RS485B) are as follows:

	
NO.	Description
1、8	RS485-B
2、7	RS485-A
3、6	GND
4、5	Internal Communication

Figure 6: Definition of Centralized Communication Interface

4. Installation and usage instructions for rack batteries

4.1. Open boxing inspection

After opening the packaging box, check whether the goods are complete according to the goods packaging list in this document, inspect the appearance of the battery pack, and confirm the integrity and correctness of the equipment;

Check if the battery case is deformed or corroded.

LFR48100 battery packing list:

LFR48100 battery pack × 1 unit

Wires × 1 set (including:

25 square 0.3m positive electrode wires × 1;

25 square 0.3m negative electrode wire × 1;

0.4m grounding wire × 1;

0.3m Ethernet cable × 1)

Instructions × 1 book (this product)

LFR51100 battery packing list:

LFR48100 battery pack × 1 unit

Wires × 1 set (including:

25 square 0.3m positive electrode wires × 1;

25 square 0.3m negative electrode wire × 1;

0.4m grounding wire × 1;

0.3m Ethernet cable × 1)

Instructions × 1 book (this product)

LFR51200 battery packing list:

LFR48100 battery pack × 1 unit

Wires × 1 set (including:

25 square 0.3m positive electrode wires × 1;

25 square 0.3m negative electrode wire × 1;

0.4m grounding wire × 1;

0.3m Ethernet cable × 1)

Instructions × 1 book (this product)

4.2. Precautions before installation

(1) Before installing the battery module, it is necessary to carefully check whether the open circuit voltage of the battery is normal, and whether there is any damage to the shell, leakage, or other phenomena;

(2) During the installation process, insulated tools and gloves should be used. Metal containing conductors such as watch bracelets should be removed from the wrist to prevent electric shock or short circuits between the positive and negative poles;

(3) The installation location of the battery should be far away from heat sources or areas prone to metal sparks, with a safe distance of more than 0.5m;

(4) Cannot connect batteries of different models, performance, and manufacturers together for use;

(5) The connection wires for battery pack installation should be as short as possible to prevent excessive line losses.

(6) Batteries should be kept away from direct sunlight and should not be placed in environments with a large amount of radioactivity, infrared radiation, organic solvent gases, and corrosive gases. They should be kept away from windows, air conditioning, exhaust fans, etc.

4.3 Installation steps:

4.3.1 Single machine use

(1) Before installing the battery, please ensure that the system end battery switch is in the OFF state to prevent ignition during installation and wiring.

(2) Keep the battery in a non working state (indicator light not on)

(3) Connect the negative terminal (P-) of the battery to the negative terminal of the system using a wire

(4) Connect the battery positive pole (P+) to the system positive pole using a wire.

(5) Connect the CAN/485 interface of the battery to the communication

port of the inverter using a communication cable

(6) After the installation of the battery system, pay attention to the insulation treatment of the battery poles and cover the insulation cover

4.3.2 Parallel use

(1) If parallel connection is required, before conducting parallel connection, please check the voltage of each battery module. The voltage difference between battery modules should be less than 2V. If it is greater than this value, please adjust the voltage through charging and discharging and let it stand for at least 15 minutes before proceeding with the operation.

(2) The parallel connection method is as follows:

Parallel connection of power lines: Use wires to connect the positive pole of the battery to another positive pole, and the negative pole to another negative pole. It is prohibited to connect batteries in series;

Communication line cascading: Connect the RS485A interface on one battery panel to the previous RS485B interface through communication lines to achieve single group automatic dialing; The CAN/485 interface of the last battery is connected to the communication port of the inverter

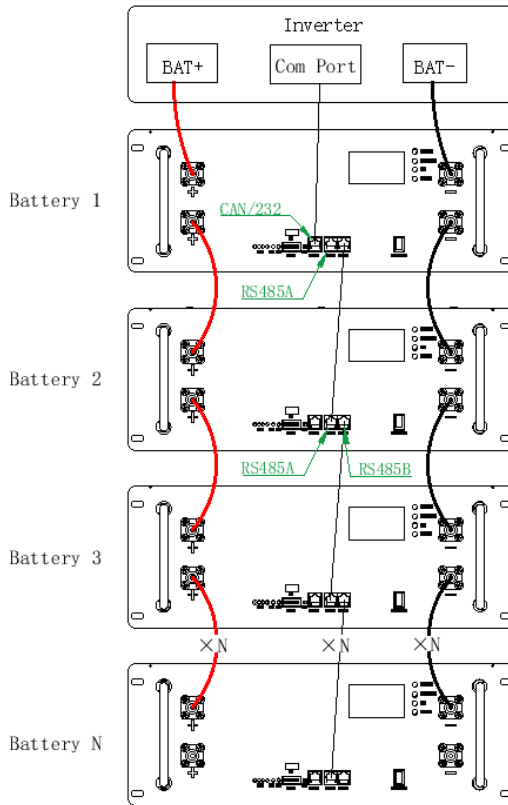

Figure 7. Parallel Connection Diagram

(3) This product supports up to 16 batteries for parallel use

(4) After the installation of the battery system, pay attention to the insulation treatment of the battery poles and cover the insulation cover.

4.4.3 Parallel dialing address selection (manual dialing method)

Definition of parallel DIP switch: In multi machine communication when the battery pack is in parallel, the DIP switch is used to distinguish different pack addresses, and the hardware address can be set through the DIP switch on the board.

Definition of dial switches bit1 to bit8: bit1 to bit4 are used to set the address, and bit5 to bit8 are used for the number of slaves.

Host settings: Bit1 to Bit4 are set to 0, the host address is fixed to 0, and Bit5 to Bit8 are set based on the number of parallel slaves.

Slave settings: Bit1 to Bit4 are set according to the device order, with a range of slave addresses from 1 to 15. Bit5 to Bit8 are fixed to 0.

Parallel use address setting: Refer to the table below for the definition of the DIP switch

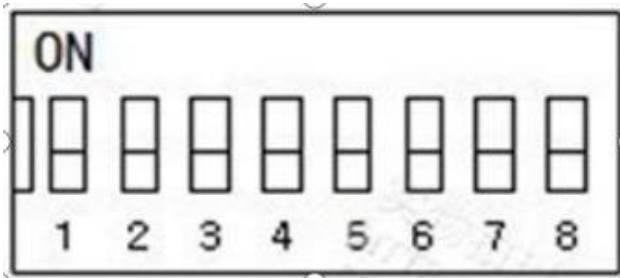

Figure 8. Definition of dial switch serial number

The method of setting address dialing for the slave is shown in Table 3:

Table 3. Slave Settings

address	DIP switch position				instructions
	#1	#2	#3	#4	
1	ON	OFF	OFF	OFF	1st slave machine
2	OFF	ON	OFF	OFF	2nd slave machine
3	ON	ON	OFF	OFF	3rd slave machine
4	OFF	OFF	ON	OFF	4th slave machine
5	ON	OFF	ON	OFF	5th slave machine
6	OFF	ON	ON	OFF	6th slave machine
7	ON	ON	ON	OFF	7th slave machine
8	OFF	OFF	OFF	ON	8th slave machine
9	ON	OFF	OFF	ON	9th slave machine
10	OFF	ON	OFF	ON	10th slave machine
11	ON	ON	OFF	ON	11th slave machine
12	OFF	OFF	ON	ON	12th slave machine

13	ON	OFF	ON	ON	13th slave machine
14	OFF	ON	ON	ON	14th slave machine
15	ON	ON	ON	ON	15th slave machine

The host setting address dialing method is shown in Table 4:

Table 4. Host setting

Number of parallel	DIP switch position				instructions
	#5	#6	#7	#8	
2	ON	OFF	OFF	OFF	2 parallel machines
3	OFF	ON	OFF	OFF	3 parallel machines
4	ON	ON	OFF	OFF	4 parallel machines
5	OFF	OFF	ON	OFF	5 parallel machines
6	ON	OFF	ON	OFF	6 parallel machines
7	OFF	ON	ON	OFF	7 parallel machines
8	ON	ON	ON	OFF	8 parallel machines
9	OFF	OFF	OFF	ON	9 parallel machines
10	ON	OFF	OFF	ON	10 parallel machines
11	OFF	ON	OFF	ON	11 parallel machines
12	ON	ON	OFF	ON	12 parallel machines
13	OFF	OFF	ON	ON	13 parallel machines
14	ON	OFF	ON	ON	14 parallel machines
15	OFF	ON	ON	ON	15 parallel machines

Example of parallel dialing code setting is shown in Table 5:

Table 5. Example of parallel dialing code

Number of parallel	DIP switch position								instructions
	#1	#2	#3	#4	#5	#6	#7	#8	
Single machine use	OFF	OFF	OFF	OFF	OFF	OFF	OFF	OFF	Single machine use

2 parallel machines	OFF	OFF	OFF	OFF	ON	OFF	OFF	OFF	1st host machine
	ON	OFF	OFF	OFF	OFF	OFF	OFF	OFF	2nd slave machine
3 parallel machines	OFF	OFF	OFF	OFF	OFF	ON	OFF	OFF	1st host machine
	ON	OFF	OFF	OFF	OFF	OFF	OFF	OFF	2nd slave machine
	OFF	ON	OFF	OFF	OFF	OFF	OFF	OFF	3rd slave machine
⋮	⋮	⋮	⋮	⋮	⋮	⋮	⋮	⋮	⋮
⋮	⋮	⋮	⋮	⋮	⋮	⋮	⋮	⋮	⋮
16 parallel machines	OFF	OFF	OFF	OFF	ON	ON	ON	ON	1st host machine
	ON	OFF	OFF	OFF	OFF	OFF	OFF	OFF	2nd slave machine
	OFF	ON	OFF	OFF	OFF	OFF	OFF	OFF	3rd slave machine
	ON	ON	OFF	OFF	OFF	OFF	OFF	OFF	4th slave machine
	OFF	OFF	ON	OFF	OFF	OFF	OFF	OFF	5th slave machine
	ON	OFF	ON	OFF	OFF	OFF	OFF	OFF	6th slave machine
	OFF	ON	ON	OFF	OFF	OFF	OFF	OFF	7th slave machine
	ON	ON	ON	OFF	OFF	OFF	OFF	OFF	8th slave machine
	OFF	OFF	OFF	ON	OFF	OFF	OFF	OFF	9th slave machine
	ON	OFF	OFF	ON	OFF	OFF	OFF	OFF	10th slave machine

									machine
	OFF	ON	OFF	ON	OFF	OFF	OFF	OFF	11th slave machine
	ON	ON	OFF	ON	OFF	OFF	OFF	OFF	12th slave machine
	OFF	OFF	ON	ON	OFF	OFF	OFF	OFF	13th slave machine
	ON	OFF	ON	ON	OFF	OFF	OFF	OFF	14th slave machine
	OFF	ON	ON	ON	OFF	OFF	OFF	OFF	15th slave machine
	ON	ON	ON	ON	OFF	OFF	OFF	OFF	16th slave machine

4.4 Switching on and running

4.4.1 Power on/start up

When the BMS is in sleep mode, press the ship type switch ON, the BMS will be started, and the LED indicator lights will flash one by one before entering normal working mode.

4.4.2 Shutdown/Hibernation

When the BMS is in standby or discharge mode, press the ship type switch OFF to put the BMS into sleep mode. After the LED indicator lights flash one by one, it enters sleep mode. BMS has no power consumption after sleep.

4.4.3 Status display

When the battery is in different operating modes, the LED lights on the panel will emit different indications

Table 6. Running status

system	running state	RUN	ALM	SOC	Instruction
--------	---------------	-----	-----	-----	-------------

state		●	●	L4●	L3●	L2●	L1●	
Shutdown	hibernate	off	off	off	off	off	off	Total extinction
Standby	normal	Flash 1	off	off	off	off	off	position in readiness
charge	normal	light	off	Always on according to battery indicator				highest LED flash 2
	Overcurrent alarm	light	flash 2	Always on according to battery indicator				
	Overvoltage alarm	flash 1	off	off	off	off	off	
	Temperature, overcurrent protection	flash 1	flash 1	off	off	off	off	
discharge	normal	flash 3	off	Always on according to battery indicator				The indicator always lights up according to the battery level
	alarm	flash 3	flash 3					
	Temperature, overcurrent, short circuit, etc. protection	off	light	off	off	off	off	Stop discharging, no action after 48 hours when the mains power is offline, forced to sleep
	under voltage protection	off	off	off	off	off	off	Stop discharging

4.4.4 Capacity display

Table.7 Capacity indication status

Status	Charging				Discharging			
Capacity indicator light	L4●	L3●	L2●	L1●	L4●	L3●	L2●	L1●

SOC	0~25%	OFF	OFF	OFF	Flash	OFF	OFF	OFF	ON
	25~50%	OFF	OFF	Flash	ON	OFF	OFF	ON	ON
	50~75%	OFF	Flash	ON	ON	OFF	ON	ON	ON
	≥75%	Flash	ON	ON	ON	ON	ON	ON	ON
RUN ●		ON			Flash				

The flashing instructions are as follows:

Table 8. Explanation of indicator light flashing

Flashing mode	Light on	Light off
Flash 1	0.25s	3.75s
Flash 2	0.5s	0.5s
Flash 3	0.5s	1.5s

5. Screen operation instructions

5.1 Screen appearance and buttons as shown in the picture:



(1) Language switching

Long press the enter button for three seconds to switch between Chinese and English.

(2) Each item starts with a number, where "number flashing" indicates the

current cursor position. Press the Up or Down keys to move the cursor position up or down, press the Enter key to enter the corresponding page, and press the RETURN key to return to the previous level of directory.

(3) In sleep mode, the backlight on the display screen goes out. Press any button to turn on the backlight on the display screen

5.2 Interface Introduction:

(1) After power on activation, the battery management interface will be displayed, and press the Enter key to enter the main page. As shown in the following figure:



Pack V: Total battery Voltage

Current: Current

SOC: Status Of Capacity

Warn: Alert

(2) Press the UP button on the pool parameter interface to access detailed battery parameter information



Cell V: Cell voltage query

Temperature: Temperature query

Warn: Alarm query

Capacity: Capacity query

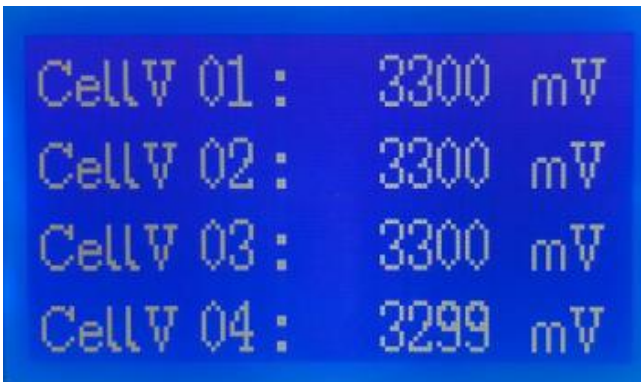

CellV01-CellV16: Cell voltage value

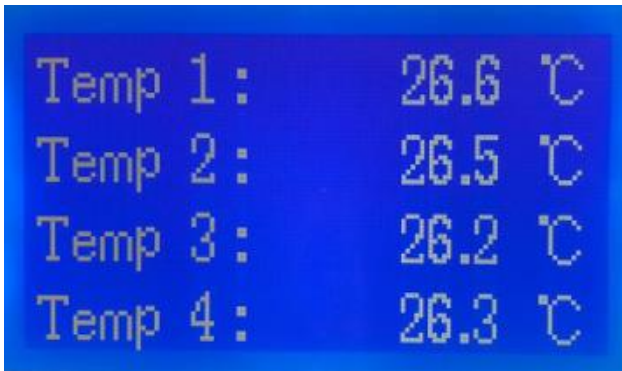

Temp1-Temp4: Cell temperature value



Envir-temp: Ambient temperature

PCB-temp: Power temperature

(3)

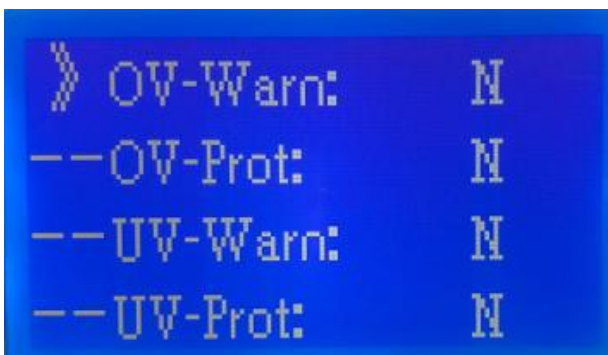

OV-Warn: High voltage warning
OV-Prot: Over voltage protection
UV-Warn: Low-voltage warning
UV-Prot: Under voltage protection

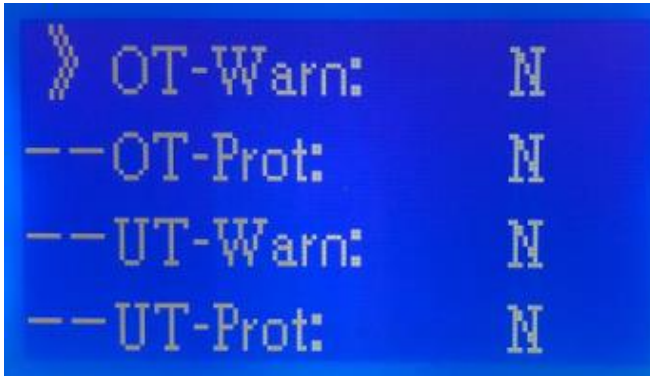

OT-Warn: High temperature warning
OT-Prot: Over temperature protection
UT-Warn: Low temperature warning
UT-Prot: Under-temperature protection

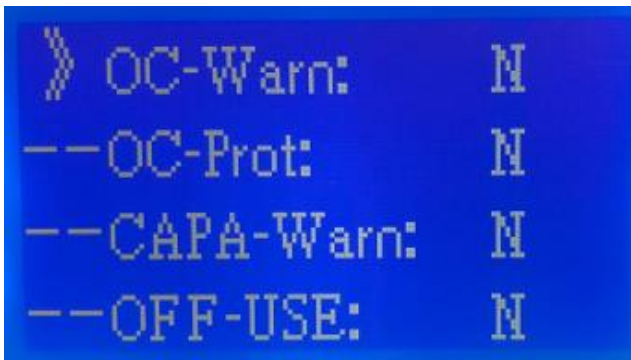

OC-Warn: Over current warning
OC-Prot: Over current protection
CAPA-Warn: Remaining capacity alarm
OFF-USE: Failure warning



SCP: Short circuit protection



FCC: Battery capacity

Rm: The remaining capacity

Cycle Time: Cycles

CAN: CAN protocol

(4) Press the Down key on the main page to enter the protocol switching interface, select the corresponding protocol, long press the Enter key for 3 seconds, and then switch to SUCCESS. The switch is complete.

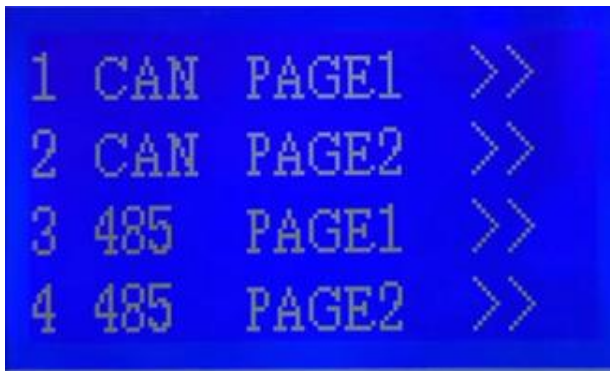

-->CAN PAGE 1

PN GDLT: Pylontech

GRWT: Growatt

VCTR: Victron

SMA SF: SMA



-->CAN PAGE 2

GINL: Ginlong

STUD: Studer



SUCCESS: Protocol switch successful

6. Storage instructions

- (1) When storing batteries, it is necessary to ensure that the SOC is \geq 50%;
- (2) The battery storage location should be dry and away from the source

of goods;

(3) Do not store batteries at high temperatures (≥ 45 °C) ;

(4) If the battery needs to be stored for a long time, it should be recharged at least once every six months

7. Declaration

7.1 Due to product version upgrades or other reasons, the content of this document will be updated from time to time. Unless otherwise agreed, this document is for instructional purposes only. All statements, information, and advice in this document do not constitute any express or implied warranties.

7.2 Before installing the equipment, please read the user manual carefully to understand product information and safety precautions.

7.3 All installation operations of the equipment must be performed by trained and qualified electrical technicians. Operators must wear personal protective equipment.

7.4 Before installing the equipment, please check the delivery items according to the "Packing List" to ensure that all the items are complete and intact, without any obvious external damage. If anything is missing or damaged, please contact your dealer.

7.5 Equipment damage caused by failure to operate according to the document is not covered by the equipment warranty.

7.6 The cable colors mentioned in this document are for reference only, and the selection of cables should comply with local cable standards.